

BRIDGE UNIT
(Machine Code: B482)

1. REPLACEMENT AND ADJUSTMENT

⚠ CAUTION

Turn off the main power switch and unplug the machine before beginning any of the procedures in this section.

NOTE: This manual uses the following symbols.

☛ : See or Refer to 🔩 : Screws 📡 : Connector 📎 : Clip ring
 Ⓞ : E-ring

1.1 BRIDGE UNIT DRIVE MOTOR REPLACEMENT

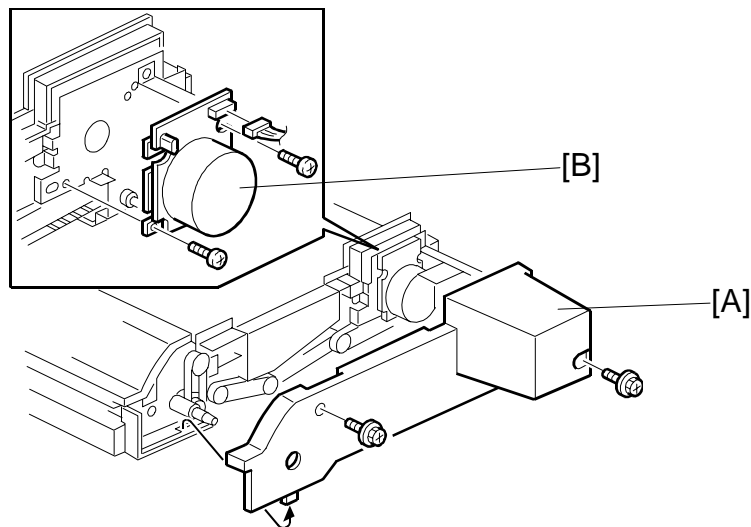

B482R103.WMF

NOTE: When taking apart the bridge unit, first take the unit out of the copier.

1. Bridge unit (☛ Installation Procedure in the base copier manual)
2. Rear cover [A] (🔩 x 2)
3. Bridge unit drive motor [B] (🔩 x 2, 📡 x 1)

1.2 TRAY EXIT SENSOR REPLACEMENT

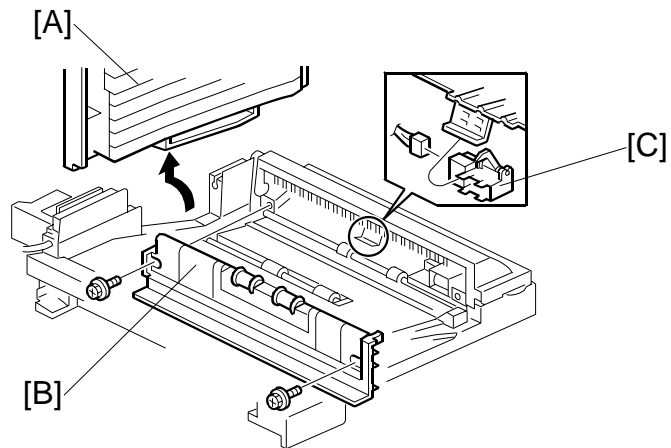

B482R104.WMF

1. Bridge unit (☛ Installation Procedure in the base copier manual)
2. Rear cover (☛ 1.1)
3. Paper tray [A]
4. Exit guide [B] (⚙ x 2)
5. Tray exit sensor [C] (🔌 x 1)

1.3 RELAY SENSOR REPLACEMENT

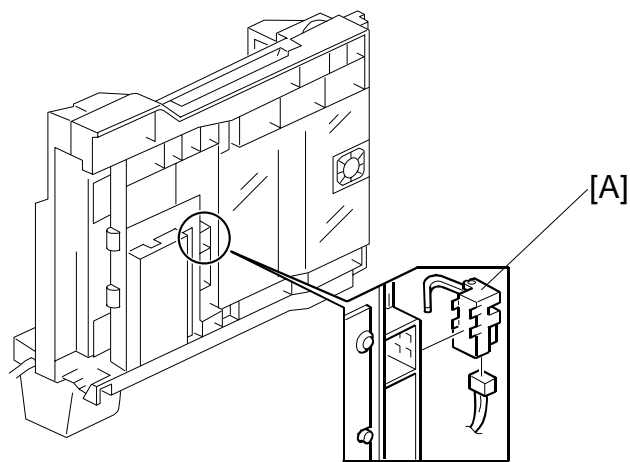

B482R102.WMF

1. Bridge unit (☛ Installation Procedure in the base copier manual)
2. Stand the bridge unit up as shown in the illustration and remove the sensor [A].

2. DETAILED DESCRIPTIONS

2.1 MECHANICAL COMPONENT LAYOUT

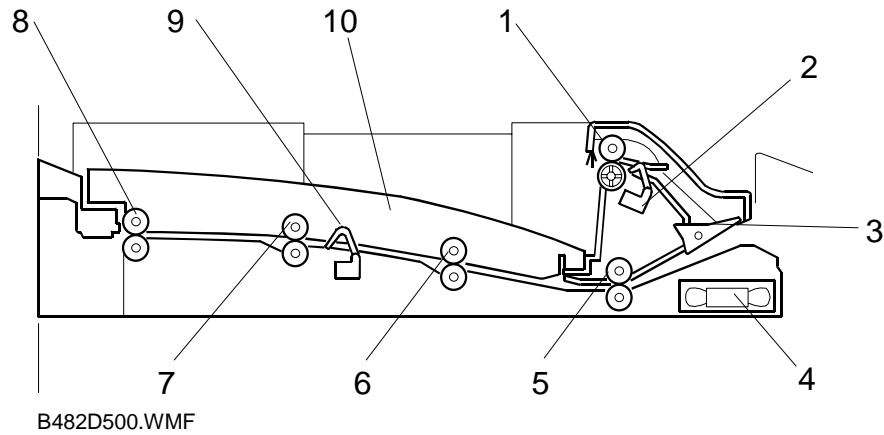

- | | |
|-------------------------|-------------------------|
| 1. Upper Exit Roller | 6. 2nd Transport Roller |
| 2. Tray Exit Sensor | 7. 3rd Transport Roller |
| 3. Junction Gate | 8. Left Exit Roller |
| 4. Cooling Fan | 9. Relay Sensor |
| 5. 1st Transport Roller | 10. Paper Tray |

2.2 DRIVE LAYOUT

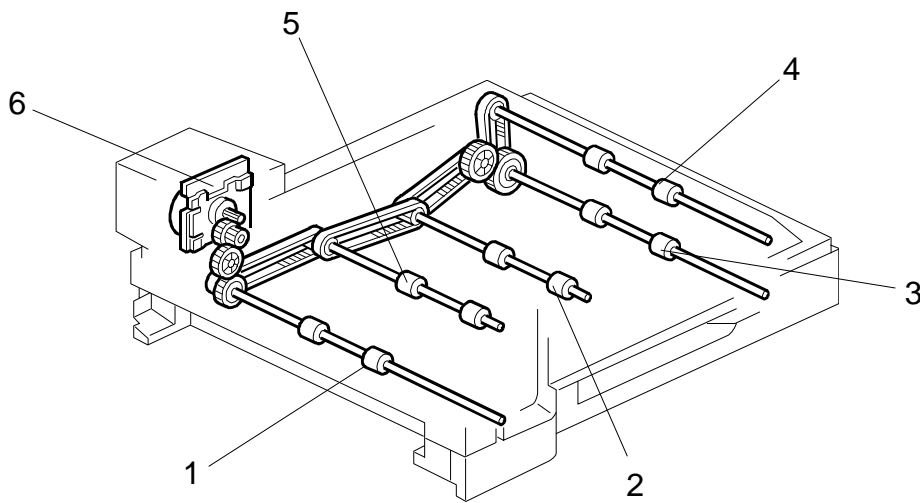

B482D502.WMF

1. Left Exit Roller
 2. 2nd Transport Roller
 3. 1st Transport Roller
 4. Upper Exit Roller
 5. 3rd Transport Roller
- Bridge Unit Drive Motor

2.3 ELECTRICAL COMPONENT LAYOUT

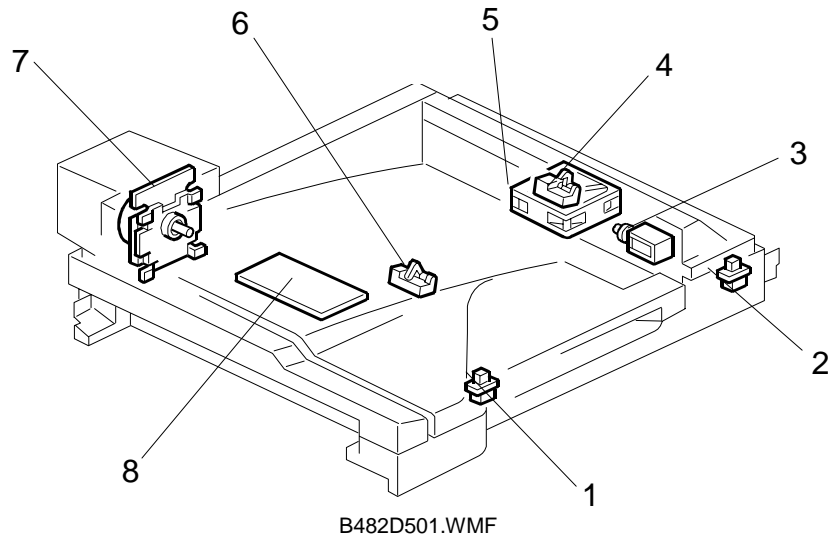

- | | |
|---------------------------|------------------------------|
| 1. Left Guide Switch | 5. Cooling Fan Motor |
| 2. Right Guide Switch | 6. Relay Sensor |
| 3. Junction Gate Solenoid | 7. Bridge Unit Drive Motor |
| 4. Tray Exit Sensor | 8. Bridge Unit Control Board |

2.4 ELECTRICAL COMPONENT DESCRIPTION

Symbol	Name	Function	Index No.
Motors			
M1	Cooling Fan	Cools the transport unit.	5
M2	Drive Motor	Drives the bridge unit.	7
Sensors			
S1	Tray Exit	Checks for misfeeds.	4
S2	Relay	Checks for misfeeds.	6
Switches			
SW2	Right Guide	Detects when the right guide is opened.	2
SW3	Left Guide	Detects when the left guide is opened.	1
Solenoids			
SOL1	Junction Gate	Moves the junction gate to direct the paper to the upper tray (on top of the bridge unit) or to the finisher.	3
PCBs			
PCB1	Bridge Unit Control Board	Controls the bridge unit.	8

2.5 JUNCTION GATE MECHANISM

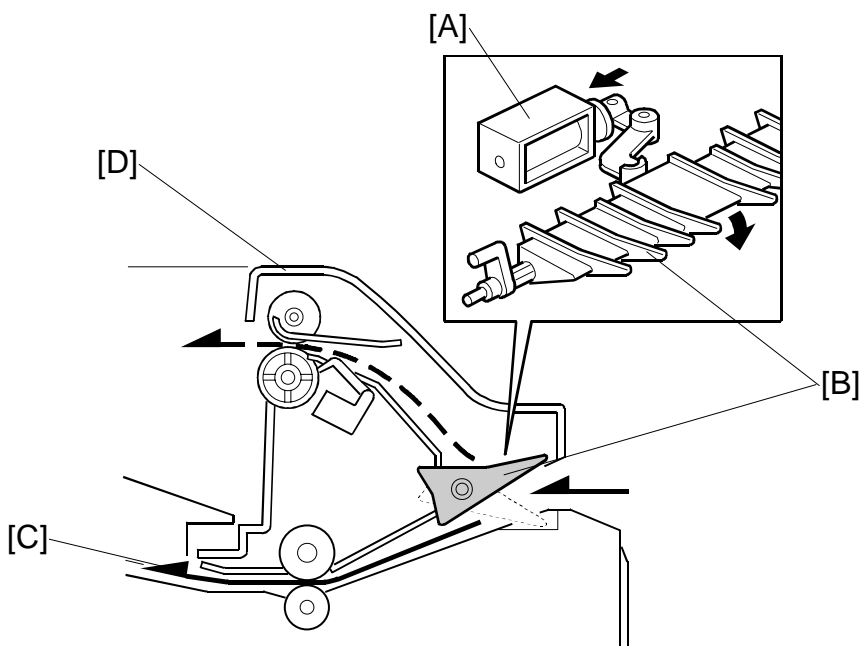

B482D104.WMF

The junction gate [B] directs any paper reaching the bridge unit to either the upper tray (on top of the bridge unit) or to the finisher, depending on which has been selected.

If the junction gate solenoid [A] has been activated, the junction gate [B] points downward and directs the paper to the upper tray [D] (dotted line path in illustration). When the solenoid is off, the junction gate points upward and the paper is fed out to the finisher [C] by the transport and left exit rollers (solid line).